



INSTALLATION & OPERATING INSTRUCTIONS CHARGER CONTROLLER

This Charger Controller (CC) is designed to replace existing controllers or timers in Portable and On Board ferroresonant chargers including Lester, Mac/Motor Appliance, E-Z Go, and like chargers. The Controller can be programmed via the Dip Switch for operation in 12, 24, 36, and 48 volt chargers. The universal mounting plate makes for easy installation in all charger cases. The capacity of this controller is for chargers having no more than 20 amps line draw at 117 volts.

Before beginning installation, unplug charger from both AC and DC power sources.

1. Remove existing timer or controller device installed in charger.
2. Install CC using the supplied screws. Use drilling template if needed.
3. Connect the red wire to battery + .Connect on battery side of fuse and/or ammeter. Connect the black wire to battery negative. Connect on battery side of fuse and/or ammeter.
4. Connect the AC cord and transformer primary as shown. **NOTE: If your charger uses SCR's instead of diodes see illustration on other side.**

DIP SWITCH SETTING:

ONLY ONE OF THESE SWITCHES SHOULD BE ON.

- Switch 4 - 12 volt system
- Switch 5 - 18 volt system
- Switch 6 - 24 volt system
- Switch 7 - 36 volt system
- Switch 8 - 48 volt system

DO NOT CHANGE OTHER SWITCH SETTINGS.

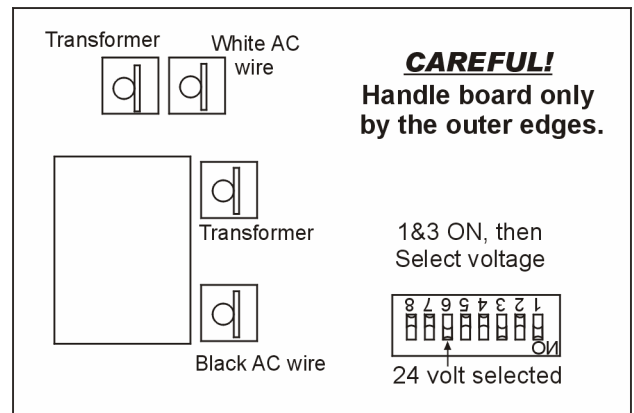

LED INDICATIONS

RED FLASH
Sampling AC & DC power applied

RED SOLID
On charge, battery less than 80%

YELLOW SOLID
On charge, battery greater than 80%

YELLOW FLASH
Battery is out of range, no charge

YELLOW RED ALTERNATING
Charge off, cycle not complete

GREEN SOLID
Charge off, cycle complete

GREEN FLASH
Charge not required

GREEN YELLOW ALTERNATING
Charger off, cycle complete

GREEN RED ALTERNATING
Charger off, cycle complete

Apply the enclosed label on the charger after cleaning the area thoroughly.

When the CC has turned the charger OFF after any charge cycle, the CC will recycle after 60 hours, if the battery is below 2.10 VPC. Removal of DC or AC power will abort the recycle.

If the controller does not operate as described, please call Quick Charge Corp.

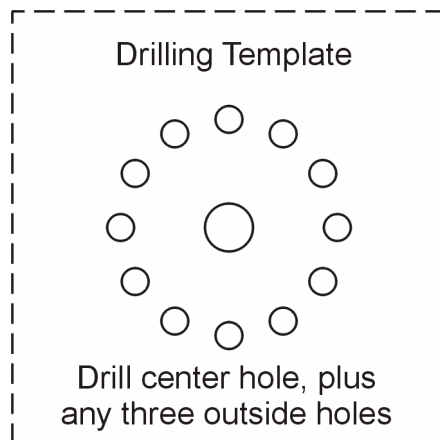

Universal Charger Controller hook up

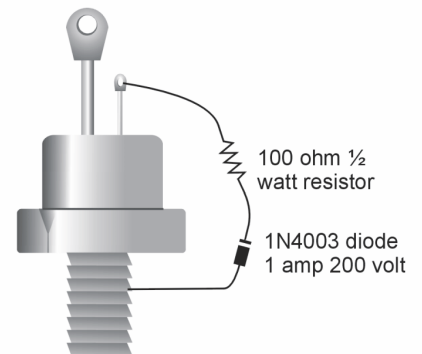
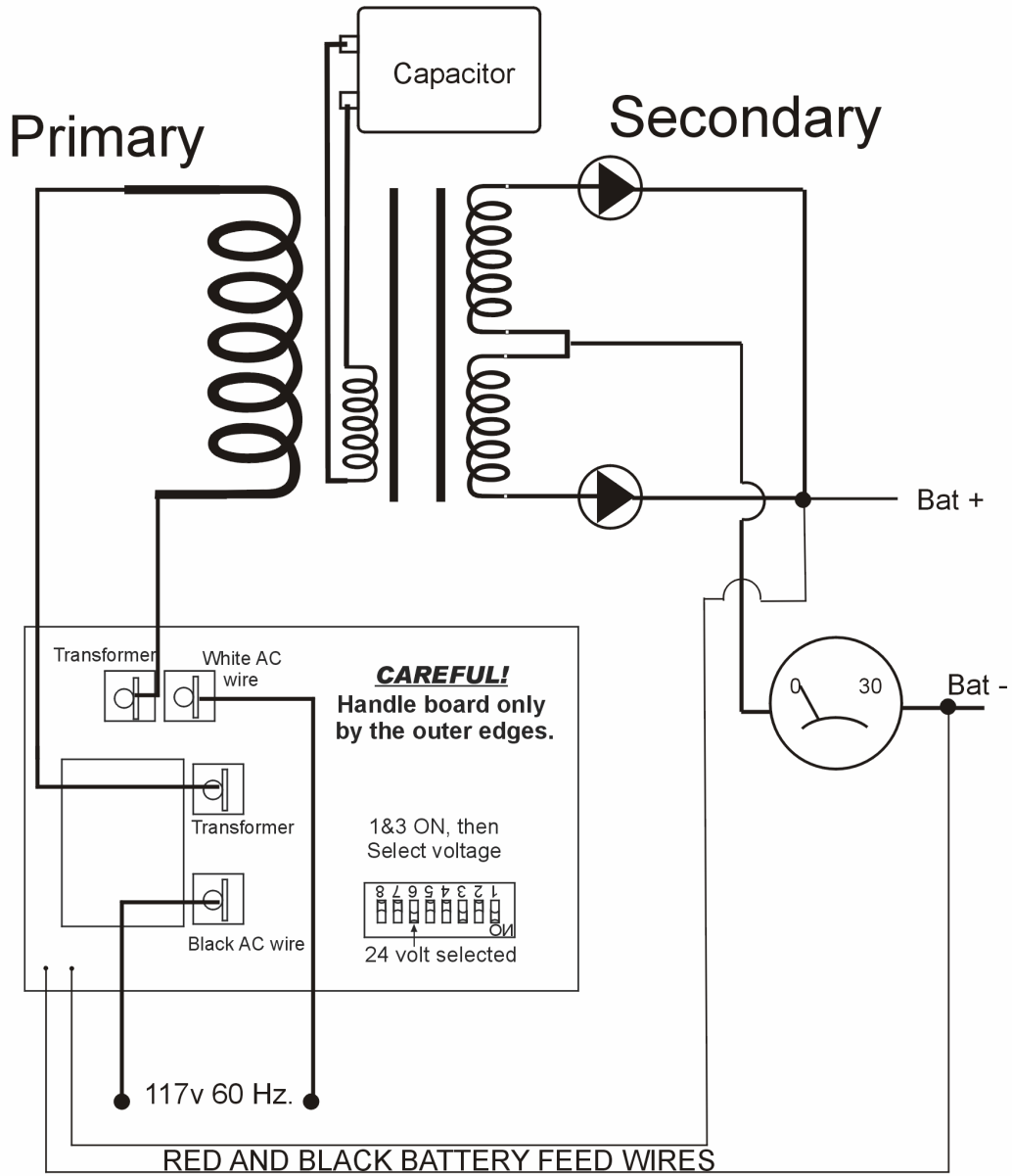

1032 S.W. 22nd St.
Oklahoma City, OK. 73109
800 658-2841 Fax (405) 632-5667 E-mail quickcharge@icnet.net

If your charger uses SCR's instead of diodes you must connect a resistor and diode as shown to each SCR.